



The TVI -VZ series two position valves are designed to control heating or cooling water. Valves are designed to withstand high moisture conditions found in many concealed installation.

Valves are operated by a hysteresis synchronous motor. Upon demand, a normally closed valve is opened by the command signal of the thermostat. When the temperature is satisfied, a spring returns the valve to the closed position. The paddle assemblies close against the flow on 2-way-valves, 3-way-valves are normally closed to the service side.

TECHNICAL FEATURES

- Main supply: 230 Vac +10% -15%, 50-60 Hz
- Power consumption: 6 VA
- Max load of the microswitch: 3 A
- Valve type: 2 and 3 way valves
- Body size: 1/2", 3/4", 1"
- Material: forged brass body, stainless steel
- base plate and bearing plate
- Body connection: FBSP parallel according to ISO 228/1-82
- Body rating: 2.1 MPa
- Fluid temperature: -10/+94°C
- Ambient temperature: -25/+60°C

Body size	Max. differential pressure (kPa) (close off)
1/2"	172
3/4"	69
1"	103

SCHEDULE

DN inches	Type	Model way	Power supply Vac	Type	Running time (s)		Auxiliary (end stroke) switch	
					open	close	with	without
1/2	TVI -VZ2-15SA	2	230	3.2	≤ 9	≤ 4		●
3/4	TVI - VZ2-20SA	2	230	4.6	≤ 9	≤ 4		●
1	TVI - VZ2-25SA	2	230	6.8	≤ 9	≤ 4		●
1/2	TVI - VZ3-15SA	3	230	4.3	≤ 11	≤ 5		●
3/4	TVI - VZ3-20SA	3	230	4.6	≤ 11	≤ 5		●
1	TVI - VZ3-25SA	3	230	6.7	≤ 11	≤ 5		●
1/2	TVI - VZ2-15CA	2	230	3.2	≤ 9	≤ 4	●	
3/4	TVI - VZ2-20CA	2	230	4.6	≤ 9	≤ 4	●	
1	TVI - VZ2-25CA	2	230	6.8	≤ 9	≤ 4	●	
1/2	TVI - VZ3-15CA	3	230	4.3	≤ 11	≤ 5	●	
3/4	TVI - VZ3-20CA	3	230	4.6	≤ 11	≤ 5	●	
1	TVI - VZ3-25CA	3	230	6.7	≤ 11	≤ 5	●	

Features:

- Compact unit - no field assembly required.
- Threaded type connections (upon request also compression pipe fitting type).
- Line - voltage hysteresis synchronous motor
- Manual operating lever included as standard to permit manual override either prior to electrical power being available or in the event of a power failure.

- Operation is silent.
- Heavy duty sector gear and spring for long lasting service.
- One piece forged brass body.
- Reliable, service-free performance.
- Models are available with an optional end stroke switch to provide valve position indication or control function such as pump or fan start/stop.
- Weight 0,92 kg

INSTALLATION

Two-way valves: When installing N.C. two-way valves, the flow direction is from end "B" to end "A" (the valve closes against the flow of the water).

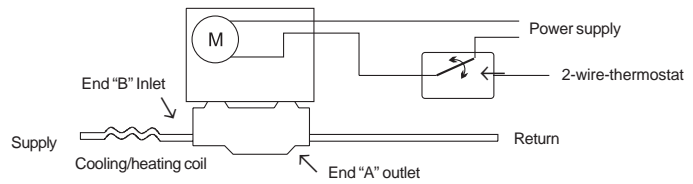

Two-way valve

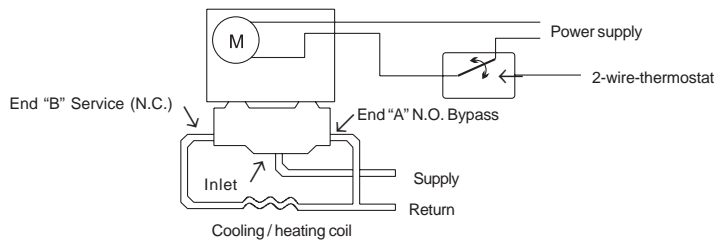

Three-way valve

Three-way valves: When installing three-way diverting valves, end "B" is the service end and end "A" is the by-pass end. The inlet part is unmarked. Port markings "A" and "B" are located on the bottom of the valve body.

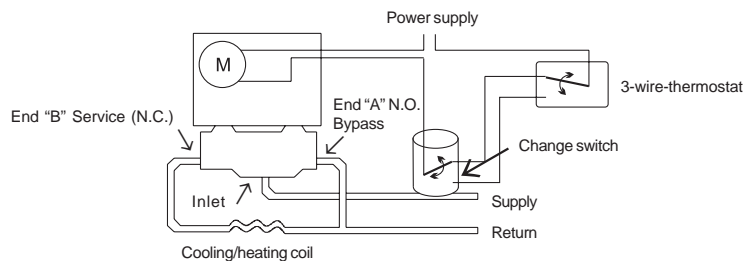

Three-way valve with strap-on change-over switch

Mounting instruction:

Electric valves, like all other mechanical equipment, should be installed with a degree of accessibility to enable quick and economical servicing or replacement. On high rise buildings, use reducing valves on branch lines on lower floors.

Important notes for fan coil installations:

Valve motor and gear train will not function properly when wet. Motor housing must be protected from drippage. Motor housing need not be protected from condensation on its attached valve body when installed in horizontal piping, if valve is positioned within 85° of upright position (see fig. 1). When mounted in vertical piping, motor housing must be protected from drippage.

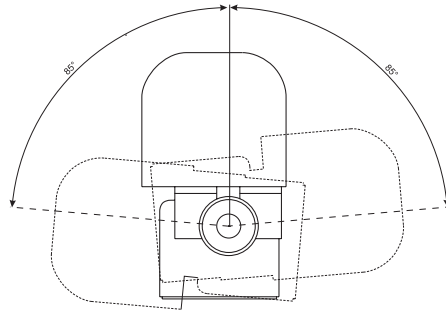

Figure 1

Manual Operating Lever:

When valves are placed in the open position with the manual lever, the paddle is removed from the seat or port. Move the lever slowly to the open position and hold in the retaining notch until the gear slack is taken up by the return spring. The manual lever will reset to the automatic position the first time the valve is cycled electrically.

Warnings:

Each operation done on the unit, either installation or maintenance, must be done without main supply on the unit. We are not responsible for possible damages caused by an inadequate installation or wrong wiring.

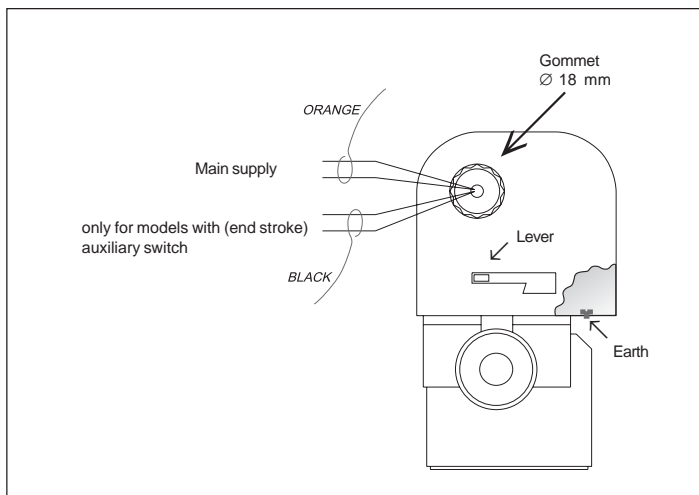

Drawing of connection wires

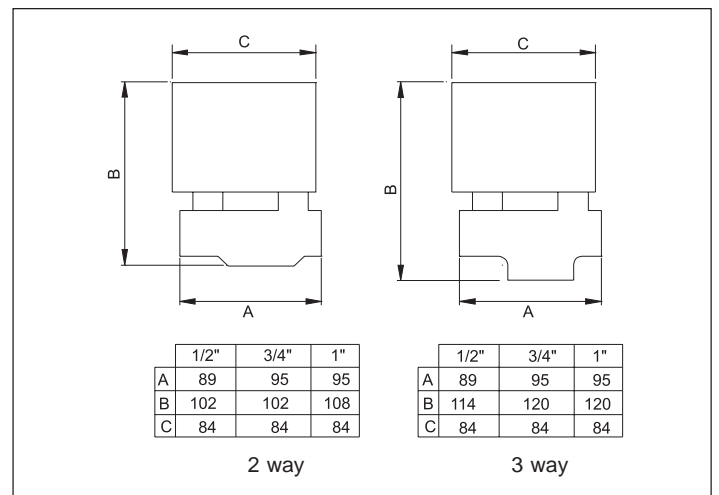

Sizes

