

TVI-SA/SM SERIES ACTUATOR

MODEL 1020 (1000N,20MM STROKE) MODEL 1520 (1500N,20MM STROKE)

DESCRIPTION

TVI-SA/SM-1020/1520 series actuator is electronic mechanic product, and can be mounted on TVI-VB32T/VB33T series valves.

Actuator has 2 basic types:

1. TVI-SA-1020 (SA 1520) reversible motor operation and provide increasing control;
2. TVI-SM-1020 (SM 1520) can accept input 0~10V DC or 4~20mA DC control signal input and provide proportional control.



(Fig. 1)

CHARACTERISTICS

- Low AC voltage synchronic reversible motor.
- Magnetism clutch.
- The action uses gear to transit. Output gear rollers are supported by surface rolling bearing, which rotate around the central bearing. The valve stem uses central rod to connect and has position indicator.
- With valve operating position pointer.
- Fireproof ABS plastic casing.
- Conveniently mounting.
- Apply to 15mm, 17mm, 19mm or 22mm stroke. As to the stroke, which has increasing or proportional control type, is selected by jumper.
- Proportional 0~10V or 4~20mA DC control can be selected direct or reversible direction operation by jumper.

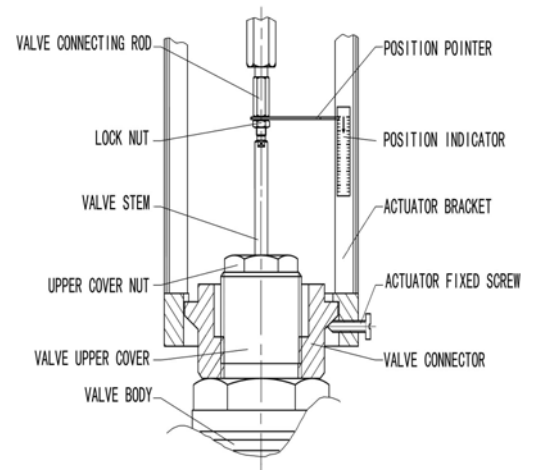

(Fig. 2)

OPERATION

1. Actuator is driven by reversible synchronous motor with magnetism clutch. Motor can create stable torsion at stopping condition depending on the magnetism effort, which is created by motor rotor and magnetism clutch. And the motor can stop at any position when there is no current pass through.
2. The signal of the increasing or proportional type controller can make the motor rotate clockwise or anti-clockwise.
3. TVI-SM-1020 (SM-1520) has a jumper, which can supply 15mm, 17mm, 19mm or 22mm stroke. Ex-factory setting is 22mm stroke. If the manufacturer has already mounted the actuator on the valve body, it will fit with the valve's stroke. TVI-SM-1020(SM-1520) also has a jumper, which can select 0~10V or 4~20mA DC control signal. Ex-factory setting is 0~10V DC mode. There is another jumper, which can select direct (DA) or reversible (RA) direction operation. The two states are opposite.

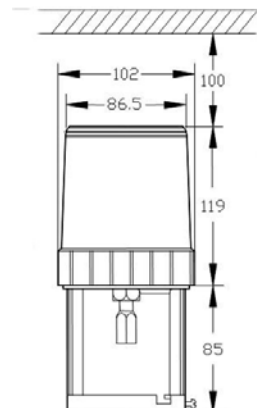

(Fig. 3)

INSTALLATION

1. Install the actuator bracket on the valve body and tighten the fixed screw of the actuator.
2. Lift up the valve stem and put the lock nut and position pointer onto it, then rotate the connecting rod of the actuator and let it rotate onto the valve stem. Use spanner to lock the locknut after adjusted the position. (See Fig. 2)
3. Give priority to vertical installation and remain enough room for screw off the actuator when repair the valve body. (See Fig.3)
4. Connect the wires according to the Wiring Diagram.
5. Electrify the actuator and make the valve fully closed, then aim at the position indicator closing line with the position pointer, and stick it tightly on the bracket of the actuator. (See Fig. 2)

NOTE

- Actuator must be protected and prevented from water dripping to destroy internal elements and motor.
- Actuator can't be covered with adiabatic material.

CAUTION

- Cut off power supply when repair the actuator, to avoid destroying elements or cause casualty because of leakage of electricity.
- When power is on, don't try to connect or disconnect the electrical wires.

SPECIFICATIONS AND TECHNICAL DATA

MODEL	TVI-SA-1020 (SA-1520)	TVI-SM-1020 (SM-1520)
OPERATION/CONTROL	Reversible and increasing control	Proportional control, direct or reversible
ELECTRICAL CIRCUIT	—	Power: 24V AC \pm 10%, 50/60Hz, Input signal range: 0~10V or 4~20mA DC
MOTOR TYPE	Bi-directional Synchronous motor with magnetic clutch.	
MOTOR ELECTRICAL RATING	24VAC \pm 10%, 50 / 60Hz, 5.5VA	
POWER CONSUMPTION OF PCB	—	2VA
NORMAL TORQUE	TVI-SA/SM-1020(1000N) / TVI-SA/SM-1520(1500N)	
MATERIAL	GEAR	Stainless steel, POM plastic (*Brass)
	REDUCER DOWN PANEL	Zinc-plated steel
	BRACKET	Die-casting aluminum alloyed
	CASING	Fire-proof ABS engineering plastic (UL94V-0)
OPERATION TIME	50Hz: 4.6s/mm (* 50Hz: 7.77s/mm)	
	60Hz: 3.8s/mm (* 60Hz: 6.45s/mm)	
ROOM TEMPERATURE	OPERATION	2~55°C
	STORAGE	-20~65°C
MAX. RH	<90% no condensation	
CONNECTING WIRES	0.5~1.5 mm ²	
EX-FACTORY SETTING	—	Stroke: 22mm; Input signal: 0~10VAC; Mode: DA
ACCESSORIES	Lock nut, position indicator, position pointer	
NET WEIGHT	1.1kg	1.15kg

TVI-SA-1020 (SA-1520) WIRING DIAGRAM

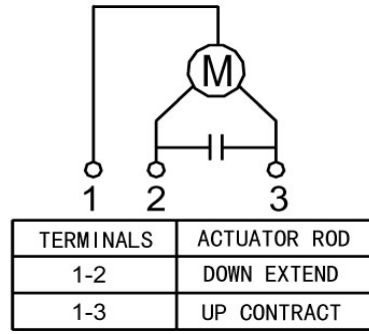

TVI-SM-1020 (SM-1520) WIRING DIAGRAM

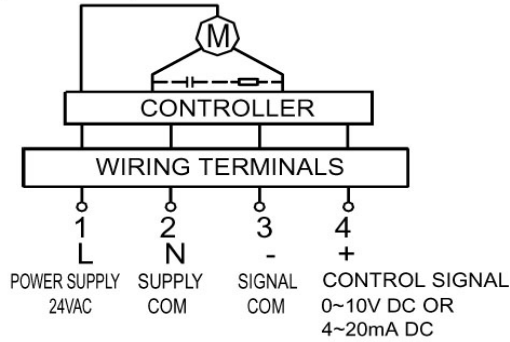

INPUT CONTROL SIGNAL		ACTUATOR ROD
DA	RA	
INCREASE	DECREASE	DOWN
DECREASE	INCREASE	UP

TVI-SM-1020 (SM-1520) PCB SETTING DIAGRAM

